

# FACTSHEET



**IRIS**  
smart cities

## Battery Energy Storage Systems Experiences in IRIS Lighthouse Cities

IRIS is a HORIZON 2020 EU funded project working to make urban environments better places for citizens and the planet. We test innovative solutions, mainstream viable technologies and explore social engagement methods to make being sustainable an easy choice... for everyone.

The three Lighthouse cities of IRIS, Utrecht, Nice and Gothenburg aim at making more efficient use of energy as part of their transition in becoming smart and sustainable cities. Stationary electricity storage solutions are a core part of this transition providing the potential for grid stability and resilience as well as flexibility services, peak shaving and peak shifting of electricity demand; thus enabling higher levels of renewable energy integration and self-consumption.

Battery Energy Storage Systems (BESS) are often demonstrated in combination with smart charging applications for electric vehicles (EV) offering storage services too. The use of stationary electricity storage at district and building level will be demonstrated in the three IRIS cities considering two types of BESS:

- New batteries specified for use in the building sector. New Lithium-Ion batteries will be used in the demo buildings of Nice and Gothenburg as well as in the Kanaleneiland-Zuid district in Utrecht.

**Co-creating  
Smart and  
Sustainable Cities**

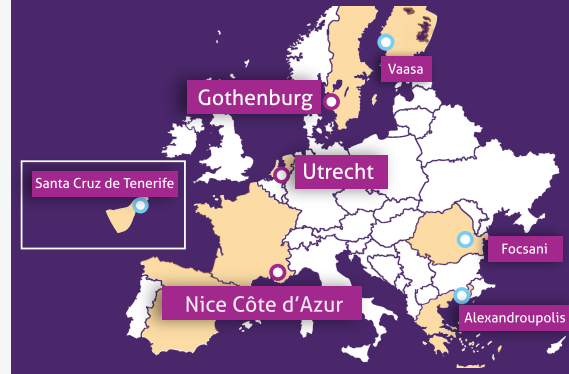

Factsheet created by

LomboXnet

bo-ex | thuis  
in Utrecht

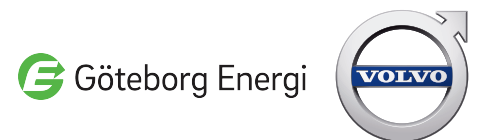

**Co-creating Smart and  
Sustainable Cities**

- 2<sup>nd</sup> life EV batteries that were previously used in electric cars or buses, repurposed to be used in stationary building applications. Re-use of former EV batteries as BESS in building applications is based on the principle that storage requirements in buildings are markedly different in comparison to mobile applications with regard to their operational characteristics, such as power and energy density. Therefore, depending on local circumstances there appears to be a good case in reusing EV batteries when they no longer meet the requirements of mobility, especially in the future as the number of available batteries increases. However, successful implementation is currently dependent on local market conditions and regulatory framework with the consideration of safety aspects. The principle of repurposing 2<sup>nd</sup> life batteries for use in the building sector is shown in Figure below. 2<sup>nd</sup> life EV BESS will be installed in the demo buildings of Nice and Gothenburg.

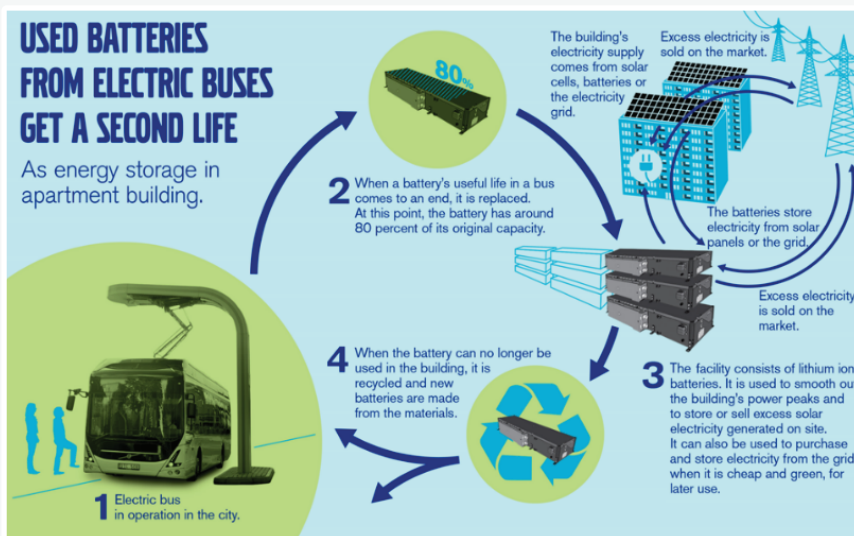

*Figure 1: Process of re-purposing EV batteries for building applications*

# Baseline (City Context)



**IRIS**  
Utrecht

**Utrecht,  
The Netherlands**

The demonstration area is situated in the district of Kanaleneiland-Zuid, a residential area of 64 hectares located in the Utrecht Centre-West area, just southwest of the historic city centre and the Utrecht Central Station. The district is a densely populated area with mostly low income households comprising approximately 40 social housing apartment buildings as well as some semi-detached and terrace houses. Kanaleneiland-Zuid district is surrounded by two large canals, one of which is used intensively for freight transport (Amsterdam-Rhine Canal) (*Figure 2*). The new district BESS will be installed in a public space outside one of twelve apartment buildings where the IRIS solutions will be demonstrated. In the baseline, there was no stationary storage of electricity in Kanaleneiland-Zuid.



*Figure 2: left) map of the Kanaleneiland-Zuid district, right) image of one of the retrofitted apartment buildings*



**IRIS**  
Nice Côte d'Azur

**Nice,  
France**

Demonstration of BESS will take place in two new buildings located in the Nice Meridia district. The Meridia district is part of the wider Nice Eco Valley area, which aims at becoming a Near Zero Energy district. The two demonstration buildings are the IMREDD building (of the Nice Cote d'Azur University) and the neighbouring Palazzo Meridia building (of the NEXITY) (*Figure 3*). The IMREDD building is a positive energy building with a total floor area of 4970 m<sup>2</sup>. The baseline condition is a 179 kWp roof-top PV system without any kind of BESS and without Smart control. The IMREDD building is further equipped with 2x 22 kW and 8x 7kW charging poles, which could further contribute to absorb the produced PV energy. Similarly, the 7862 m<sup>2</sup> big Palazzo Meridia office building is with 35 m height, the highest wood building in France and the only office building in the country having achieved the "E3C2" labelling. It is equipped with an 89 kWp roof-top PV system, thought to cover about 65% of the building needs.



*Figure 3: Palazzo Meridia building and the IMREDD building on the right hand side. (Source: © Y. Bouvier for Nexity)*

In Gothenburg stationary storage systems will be demonstrated in two types of buildings, i.e. an office building called 'A Working Lab' (AWL) built by Akademiska Hus and apartment building 'Viva' constructed by Riksbyggen in collaboration with other local actors. 'Viva' comprises 132 apartments and was subsequently sold to Viva housing association. It is envisaged that 'Viva' will be the most innovative and sustainable housing project in Sweden. The 'AWL' building is located in the Johannenberg campus of Chalmers University, whilst 'Viva' is located at the vicinity of the campus. The baseline condition of the 'AWL' building is that there is no BESS. A 200 KWp roof-top PV system is installed but there was no provision for electrical storage. 'Viva' is a new building with a 170 KWp roof-top PV system. The baseline condition for 'Viva' did not consider BESS.



*Figure 4: The AWL building (left) and the Viva building (right)*

# Demonstration



Utrecht,  
The Netherlands

In Utrecht, the district wide BESS will facilitate the electricity needs of 12 apartment buildings. A new Lithium-Ion battery pack with a total capacity of 845 kWh and power rating of 590 kW/630 kVA will be installed in a public space of the neighbourhood. The battery is interconnected to a PV system and a V2G (Vehicle to Grid) EV sharing system (5X22 kW AC-V2G charging stations in the project area, capable of bidirectionally charging 10 EVs using the open ISO15118 protocol), and to a fast-growing, city-wide flexibility network of 300 AC-V2G charging stations (400 expected by end of 2020). In the area, a new OCPI-interconnectivity between the charging stations and the local transformer station will be tested, as preparation for upscaling to district-level energy management between charging stations and transformer stations in the whole city, taking into account the availability of sustainable electricity production.

The BESS will be probably installed next to a new-built transformer house outside the building 'Magelhaenlaan I' as shown in *Figure 5* below. It will also include bi-directional inverters with DC-to-DC converter as well as a new transformer station for the grid connection. The system has a 10-year warranty (that can be extended to 15 years) and complies to IEC 62109, UL 9540, UL 1741 and other standards.



*Figure 5:* view of the transformer house next to which the BESS will be installed

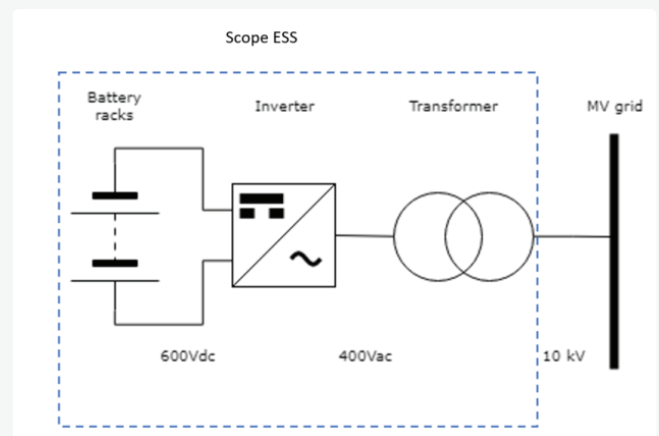

*Figure 6:* Electric connection of stationary battery (source: RFP energy storage system)

The BESS will deliver flexibility to the Transmission System Operator (TSO), local flexibility and store PV-power. This is achieved through the Tesla Powerpack Controller battery software that is able to respond to flexibility requests from the DSO with flexibility and price offers. The technical specifications and capabilities of the battery software are:

- Ability to communicate with external controllers
- Onsite monitoring of Site power, Site reactive power, Battery power, Energy available, Energy remaining, Energy exported/imported @ battery meter, Voltage, Current, Power targets
- Telemetry for Powerpack, solar PV, net load at grid interconnection, and 3rd party generation assets, for a fully-integrated view of the site
- Compatibility with LomboXnet system and District Energy Management System
- Ability to make flexibility offers to DSO upon request conform specifications of USEF/GoPacs



**IRIS**  
Nice Côte d'Azur

**Nice,  
France**

The two demonstration buildings will both be equipped with a dedicated BESS, located within the building premises (underground parking). In the IMREDD building, a new Li-Ion 100kW/150 kWh has been delivered, together with two 18 kWh/10 kW 2<sup>nd</sup> life EV BESS, the 10 before said EV charging poles and moreover, it integrates a 22 kW charging pole for the Renault Zoe V2G AC prototype (V2G). In general terms, the aim of the Nice demonstration is to integrate such systems under a smart Energy Management System (EMS). This will enable, in a first step, to achieve PV surplus minimization by the control of the BESS and the EV charging poles charging/discharging. Additional aim is to compare the performance and aging of the 2<sup>nd</sup> life BESS to the new BESS on one side, and compare its performances to that of V2G technology on the other side. In order to control the 2<sup>nd</sup> life BESS, a dedicated EMS will be set up as well as a related experimentation calendar.



**Co-creating Smart and  
Sustainable Cities**

In the Palazzo Merida building, the system is similar: the installed EMS will control a 66 kW/90 kWh Li-Ion BESS and once the building owners will start equip themselves with EV, it will also integrate the control of the EV charging poles. Different from the IMREDD building, this is regulated under a “common-self consumption” endeavour. The coupling of the new BESS and the control of the charging poles (V1G and V2G), will be further extended in both buildings, by coupling the EMS with an aggregation platform. The aim is to test the feasibility to use the BESS and the V2G charging pole to provide flexibility to the electric grid. At first, it is planned to provide primary reserves for the electricity spot market (Day-Ahead), while other services might be added within the project duration.

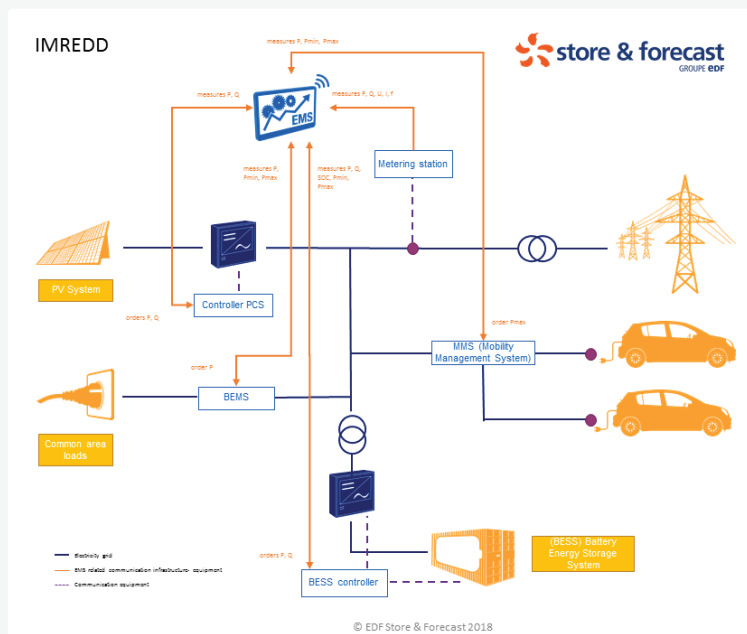

**Figure 7:** physical and ICT interconnections between the EMS and the technologies integrated in the IMREDD building



**IRIS**  
Gothenburg

**Gothenburg,  
Sweden**

In Gothenburg both new and 2<sup>nd</sup> life stationary battery systems will be used in the two demonstration buildings. A new 200 kWh/96 kW LiFePO4 BESS will be used in combination with a 174 kWp PV system in the AWL building as part of a 760V DC microgrid. In this project, Akademiska Hus will explore the benefits of using DC electricity produced by the PV directly and demonstrate the efficiency of a DC system compared to an AC system. The PV produced electricity (optimised by solar string optimisers) is delivered to either i) the DC connected BESS, ii) DC loads of the building or iii) converted to AC supplying the AC loads of AWL and then the distribution grid (**Figure 8**).



**Co-creating Smart and  
Sustainable Cities**



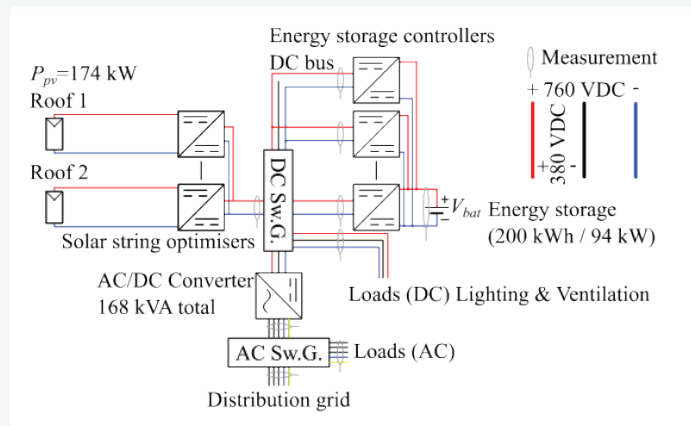

**Figure 8:** Schematic overview of AWL system depicting main components (PV, DC-connected energy storage, DC and AC switchgears, DC and AC loads)

Batteries will provide the necessary storage capacity for increased self-consumption / autonomy. The BESS will operate either for:

- a) maximising self-consumption where the batteries are charged only from the PV and feed the internal DC - AC loads or
- b) limiting the current where a maximum level of power is allowed to be drawn by the AC load; the BESS is discharged if this limit is breached and in this case it may be charged from the grid. Control of the system and power distribution will be achieved through specialized built-in software in the system components (Ferroamp, Webport, Wepfactory) and through the communication of the AWL BEMS with the specialized software.

The demonstration in the Viva buildings aims at evaluating the effectiveness of using 2<sup>nd</sup> life EV batteries in building applications. The 2<sup>nd</sup> life BESS will primarily provide power peak-shaving and increase self-consumption of a 170 kW PV system installed on the roof of the building. Secondly, it can be used to purchase and store electricity from the grid for later use or reselling. The BESS is comprised of 14 Li-Ion batteries (LFP - Lithium FerroPhosphate, or Lithium-Iron-Phosphate) that have previously been used to power buses in public transport in Gothenburg. This battery type offers a very low Cobalt content, whilst it is mainly composed of common metals. The BESS is controlled by EnergyHub, a system developed by the subcontractor FerroAmp. EnergyHub connects units and devices, also acting as the connector to the electricity grid. In Viva, the system is programmed to keep the power injection from the grid below a set level. This level is set manually and preferably it will be updated along the seasons.

# Societal, user and business aspects

## Societal, user, citizen engagement

### Utrecht, The Netherlands

The BESS in Utrecht aims at providing grid stabilization and resilience contributing to the city's 'virtual power/storage plant' that will decarbonize the city's energy mix. Bo-Ex, the owner of the apartment buildings is also the owner of the battery system; LomboXnet is the battery operator and the municipality of Utrecht ensures public support of the project.

Initially, 2<sup>nd</sup> life EV BESS was considered to be used with batteries installed at the garage boxes of each building. However, due to safety reasons and the fact that new batteries offered increased capacity compared to 2<sup>nd</sup> life for the same cost, it was decided that a central BESS with new batteries would be installed in a public space. Despite the obvious benefits of re-using the batteries (extending their lifetime, delaying recycling process and increasing the value of the batteries over their lifetime), 2<sup>nd</sup> life batteries, being a young technology, are hardly available on the Dutch market and currently much more expensive than new batteries, for which the production costs have dramatically dropped due to volume upscaling. New legislation that will support similar demonstration projects is required in order to investigate different exploitation and business models and enable market growth.

User engagement will focus on the embedding of the BESS in its surroundings. School children and citizens are involved in a citizen engagement activity to create the best and green looking decoration of the battery, thereby providing the opportunity to engage them in energy topics.

### Nice, France

The operation of the two EMS will be extended in a stepwise approach: at delivery of the BESS, the EMS operated by EDF Store&Forecast, will work in a "self-consumption" maximisation mode, with probably no grid injection. Once the terms of grid-injection will be settled for the buildings, it will integrate PV surplus resell to the grid. In parallel, the coupling with the aggregation platform will be tested and once its reliability can be proven, grid- services are planned to be activated.

As mentioned previously, the 2<sup>nd</sup> life BESS in the IMREDD building will be operated in a different logic and in alternation with the main EMS: 2<sup>nd</sup> life EV BESS is not a mature technology, with a very limited number of providers in the French market offering specialised non-standardised solutions (so about TRL 8), the solution is known to be not cost-competitive. Furthermore, there is a great deal of scepticism on their use due to the lack of evidence on their operational characteristics such as aging or durability. Results from the demonstration will provide valuable information on characterising the performance of 2<sup>nd</sup> life BESS and their aging degradation rate and compare that to the respective characteristics of the new EV storage system and as said, to its competitiveness compared to V2G technology. Such information is unique to the French context and Nice Cote d'Azur University/IMREDD which is the owner and user of both storage systems will integrate them into their educational work program.

## Gothenburg, Sweden

Stationary storage, both new and 2<sup>nd</sup> life BESS, that will be used at the two demo sites are expected to increase the self-consumption of the PV produced electricity and to support grid flexibility. Akademiska Hus is the owner of the AWL building and takes all final decisions, while technical expertise and research development is provided by Chalmers University of Technology and consulting company ÅF. The Association of Viva is the owner of the Viva buildings, however Volvo owns the batteries and associated control equipment.

The Swedish regulatory framework supports self-consumption of the generated energy, increasing the incentive for local energy storage. Despite the favourable regulatory framework, there were still barriers to overcome. In the AWL building, the lack of available DC equipment was identified as potential barrier to the development of similar DC microgrid projects. With regard to the Viva building demo, fire safety regulations were found to be a potential barrier in the wider use of 2<sup>nd</sup> life EV batteries. Specific guidance from the fire brigade was expected for the installation of the BESS and this caused delays in the project progress. Nevertheless, the stationary 2<sup>nd</sup> life BESS is now installed and will provide valuable information on the performance of such system and the assessment of their degradation rate. Once the BESS become obsolete, it will be recycled following the relevant legislation.

In terms of user engagement, Brf Viva residents can monitor the energy balance as well as heating, water and electricity consumption of their households through the dedicated resident's app. Furthermore, solutions implemented at the Viva building receive large coverage from Riksbypgen's collaborative research and innovation platform, Positive Footprint Housing.

## Business and Value Proposition



### Utrecht, The Netherlands

The business model in the Dutch demonstrator is based on supplying flexibility to the Dutch TSO (Tennet) as well as negotiating local flexibility with the DSO. However, the business case for the stationary BESS and smart energy management system is at this moment hampered by regulations and taxation. Current regulation restrictions do not allow optimum use of the BESS for maximizing PV self-consumption whilst battery electricity is subject to double taxation hampering the viability of the stationary storage applications. IRIS partners LomboXnet and Stedin have brought these regulatory issues to the attention of the EC and the public in several ways, including actively contributing to the EC Innovation Deal on electric vehicles<sup>1</sup>.

<sup>1</sup>[https://ec.europa.eu/info/research-and-innovation/law-and-regulations/innovation-friendly-legislation/identifying-barriers/signed-innovation-deals\\_en#emobility](https://ec.europa.eu/info/research-and-innovation/law-and-regulations/innovation-friendly-legislation/identifying-barriers/signed-innovation-deals_en#emobility)



### Nice, France

The reuse of 2<sup>nd</sup> life EV batteries is believed to provide an important value proposition for the whole BESS and automobile industry, extending their lifetime and displacing BESS recycling further in the future. However, the lack of standardisation of these products in the French market and the lack of evidence on their performance and operational characteristics is making investment in such systems less attractive. Stakeholders appear to be reluctant on their use.



Co-creating Smart and  
Sustainable Cities

Results of the demonstration will provide unique information on the aging process of 2<sup>nd</sup> life BESS and their performance on building applications leading to awareness about the technology and possible market uptake of these products. The comparison to the new V2G technology should provide additional insight: indeed, if smart charging services of V2G technologies integrated in building can be used to provide similar services as 2<sup>nd</sup> life BESS with equivalent, or even better, reliability and performances, the question regarding the competitiveness of 2<sup>nd</sup> life BESS will be raised. In this case, a complete overhaul of EV batteries might be more interesting for the car and battery industry, as 2<sup>nd</sup> life BESS and V2G technologies in buildings are competing for the same very limited market space; 2<sup>nd</sup> life BESS risk to be phased out if no technological breakthrough is achieved.

Similarly to 2<sup>nd</sup> life batteries, the economic aspect behind the overall integration of new Li-Ion BESS with a PV-based self-consumption endeavour in the French context, is yet not a fully viable business model: the integration of a BESS under current French grid code and applicable grid- and retail- tariff systems, delays the ROI of a couple of years (even annihilating it if the system is oversized). However, it is expected that by providing grid services, the delay in the ROI due to the BESS might be considerably reduced, if not totally removed.



**Gothenburg,  
Sweden**

The business model of the AWL system is based on the more efficient use of PV electricity when it is used directly by DC equipment, leading to 3-5% higher yields with the battery systems increasing the degree of self-consumption. The business proposition of the AWL pilot is based on the replication of the measure on the other Akademiska Hus buildings. This will lead to an increase in the demand of DC equipment and support their market uptake.

In Viva, the use of 2<sup>nd</sup> life EV batteries offers the benefits of extending their useful lifetime and their value over their lifecycle. 2<sup>nd</sup> life EV batteries still operate at about 70-80% of their initial capacity when repurposed as stationary building BESS. Taking advantage of these different demand specifications of mobile and building applications leads to a business model that fits well to the type of extended service life that vehicle manufacturers like Volvo are seeking, to improve the value and overall sustainability performance of their products. Successful demonstration of this storage solution may lead to future mutually beneficial collaborations between vehicle manufacturers and building developers unlocking the supply potential required for achieving economies of scale.



**Co-creating Smart and  
Sustainable Cities**

# Impact management strategy

Of the three Lighthouse cities, the Municipality of Utrecht has established a rational impact management strategy for their demonstration and scale up of BESS system on their city market.

## Why:

The BESS system in Utrecht aims at providing grid stabilization and resilience contributing to the city's 'virtual power/storage plant' that will decarbonize the city's energy mix.

## How:

The municipality of Utrecht ensures public support of the scale up project. However, the business case for the stationary battery and smart energy management system is at this moment hampered by regulations and taxation. Current regulation restrictions do not allow optimum use of the BESS for maximizing PV self-consumption whilst battery electricity is subject to double taxation hampering the viability of the stationary storage applications. A change of regulations is under discussion on a EU-wide level.

## What:

The future values chain and business models on the Utrecht market will be based on supplying flexibility to the Dutch TSO (Tennet) as well as negotiating local flexibility with the DSO. Examples of two actors in such a value chain are: Bo-Ex, an owner of apartment buildings and owner of battery system and LomboXnet the service provider for battery operations.

## Expected Impacts



### Utrecht, The Netherlands

The BESS in the district of Kanaleneiland-Zuid is expected to provide valuable contribution in grid resilience and stabilization as well as contribute to the city-wide 'virtual power / storage plant' providing flexibility services and reducing peak electricity demand.

Key Performance Indicators that will be used to quantify performance of the BESS are:

- **Storage capacity installed.**  
The new district BESS will have a capacity of 845 kWh compared to 0 kWh in the baseline.
- **Peak Load Reduction.**  
No specific target has been set on the BESS, however it is aspired that at least 10% peak load reduction is achieved due to the combined effect of BESS with the PV and the smart DEMS (District Energy Management System).



### Nice, France

The implementation of BESS and their coupling via an EMS to the aggregation platform is expected to increase the share of locally available renewable energy on one side and on the other, to improve their integration in the overall energy system, contributing to the stabilization and resiliency of the electric grid. In addition, the 2<sup>nd</sup> life BESS use-case is research-intensive and is expected to lead to valuable and unprecedented information on the performance and aging of 2<sup>nd</sup> life EV BESS as well as on their techno-economic assessment in comparison to new V2G storage systems.

These impacts will be quantified with the use of the following KPIs:

- **Useful storage capacity installed.**  
This is the cumulative activated capacity of all BESS and activation of EV related capacities (V1G and V2G).
- **Degree of renewable energy self-supply.**  
Ratio of locally produced renewable electricity by the energy consumption of the building.
- **Battery degradation rate.**  
This will be determined through monitoring the nominal and final capacity of the 2<sup>nd</sup> life BESS as well as the number of cycles per year that the battery is performing.
- **Peak load reduction.**  
This is the ratio of the measured to the baseline peak load.



Co-creating Smart and  
Sustainable Cities

Stationary storage technologies, both new and 2<sup>nd</sup> life BESS, that will be used at the two demo sites are expected to increase the self-consumption of the PV produced electricity and to support grid flexibility. Successful implementation of the two demo projects is expected to lead to:

- Increase in self-sufficiency of buildings with higher levels of locally produced electricity consumed on-site.
- Better understanding of the use and performances of stationary storage systems
- Higher levels of flexibility services and choosing when to import/export energy
- Reducing peak loads and carbon emissions

Suitable Key Performance Indicators will be used for quantifying the aforementioned impacts:

**1. The Degree of Renewable Energy Self-supply.**

This is the ratio of the locally produced electricity by RES and the building's total electricity consumption. In the AWL building, the target for self-consumption is 10% (from a baseline of 0%). In Viva, it has been estimated that the use of the 200 kWh battery system will result in selling 4% of the PV produced electricity to the grid. In case of no storage system installed, the respective amount of electricity would be 20%.

**2. Peak Load Reduction.**

A target of 80% peak load reduction compared to the baseline has been set in the AWL building. The target for Viva has been set to 25% reduction compared to the baseline.

**3. Battery degradation rate.**

The degradation rate of the batteries per year and the degradation rate per energy unit may be determined through monitoring specific parameters during the operation of the BESS systems (amount of energy taken out from the batteries over time, time in use, load cycled of the batteries and their storage capacities).



# Lessons Learnt

## Utrecht, The Netherlands

Through the implementation of the Utrecht demonstration project it has been found that 2<sup>nd</sup> life EV batteries for building applications are relatively expensive especially compared to new batteries, for which the prices have fallen steeply over the last years. The cost of 2<sup>nd</sup> life batteries is currently high as a result of low levels of supply (EV batteries appear to have longer than expected lifetimes on mobility applications) and high levels of demand from multiple innovation projects. Another lesson learnt from this project was that installing the 2<sup>nd</sup> life batteries in the garage boxes of the buildings was not acceptable due to the size of the garage boxes and safety concerns. Therefore, a first tender for 2<sup>nd</sup> life batteries installed in the garage boxes did not lead to an acceptable outcome. A second tender was conducted for a central BESS and a bid for a new battery system offered 50% increased capacity compared to the 2<sup>nd</sup> life one for the same price. For this reason, a central new BESS was selected as the most financially viable and technically feasible solution.

## Nice, France

The progress of the French demo pilot has led to lessons learnt on the marketability and technology readiness of BESS in the French context. First assessments have shown that a BESS for a self-consumption application might degrade the overall business model if not alternative services are proposed. Moreover, the whole value chain has been experienced (from tendering to installing of the BESS) and it has emerged that the building and engineering industry is yet not totally prepared for the uptake of such technology. Furthermore, it has been apparent that the BESS regulation in the building sector is not sufficient to provide an efficient guide to the industry yet. Industrial expertise and knowledge is currently bounded to few companies that have undertaken first pilot projects and only such companies have experience with regulation related issues regarding BESS integration in the building sector (as fire-safety or system acceptance procedures for certification and inspection offices). Such knowledge gap can cause very costly additional building and safety measures during building construction, accompanied by additional delays in the work plan.

It has been also found that 2<sup>nd</sup> life EV BESS solutions are currently lacking standardisation with few suppliers offering specific solutions hindering their widespread use. Furthermore, these systems appear less competitive to new BESS for building applications due to their increased cost and larger volumes required (as a result of lower energy density). Stakeholders also seem reluctant on their use due to perceived uncertainties related to their performance. Finally, French regulation is not taking into consideration in detail the specifications for decentralised building integrated solutions, hampering the development of standardised solutions and adoption of this technology on a larger scale. These challenges will need to be overcome for a wider uptake of this technology to the market.

## Gothenburg, Sweden

The Swedish demo in AWL was found to run smoothly with no major issues hindering the use of the BESS. Preliminary results from the Viva demonstration suggest that the use of 2<sup>nd</sup> life bus batteries for stationary BESS and for storing locally produced solar electricity was beneficial and has significant potential to contribute towards mitigating the environmental cost of automotive batteries on a systemic level. Nevertheless, being a first of a kind installation meant that there had been some unforeseen issues with serviceability. Wider application of 2<sup>nd</sup> life BESS and increased experience on their operation will contribute to their wider use and the seamless integration of such systems in building applications.



**IRIS**  
smart cities

Co-creating Smart and Sustainable Cities

Follow our story



@IRISsmartcities



irissmartcities.eu

